



Duschhocker
Gebrauchsanweisung

Sgabello per la doccia
Istruzioni per l'uso

Suihkujakkara
Käyttöohje

Shower stool
Operating instructions

Taburete de ducha
Manual de instrucciones

Dusjkrakken
Bruksanvisning

Tabouret de douche
Mode d'emploi

Banco de duche
Manual de instruções

Badetaburet
Betjeningsvejledning

Douchekruk
Gebruiksaanwijzing

Duschpallen
Bruksanvisning

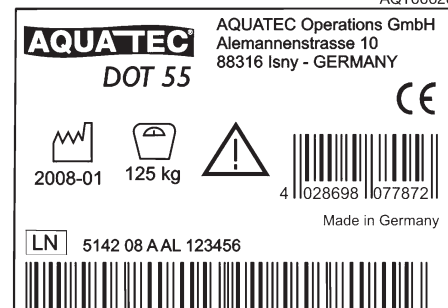
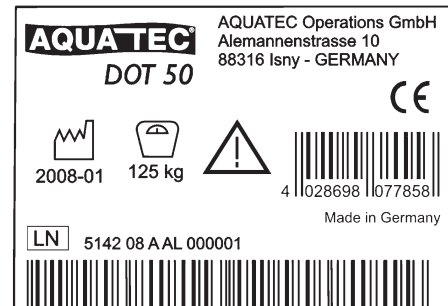

Sicherheitshinweise
Safety instructions
Consignes de sécurité
Veiligheidsinstructies
Indicazioni di sicurezza
Indicaciones de seguridad
Instruções de segurança
Säkerhetsanvisningar
Turvaohjeet
Sikkerhetshenvisninger
Sikkerhedshenvisninger



Hockerposition beachten
Note stool position
Respecter la position du tabouret
Let op de positie van de kruk
Osservare la posizione dello sgabello
Prestar atención a la posición del taburete
Observação sobre a posição do banco
Beakta pallpositionen
Huomaa jakkaran paikka
Vær oppmerksom på plassering av krakken
Vær oppmerksom på taburettens position



Bei Defekt nicht verwenden
Do not use if defective
Ne pas utiliser en cas de défaut
Indien defect niet gebruiken
Non impiegarlo se difettoso
No utilizar en malas condiciones
Não utilizar se estiver danificado
Använd inte produkten om den är trasig
Älä käyttää viallista tuotetta
Må ikke brukes når den er defekt
Må ikke anvendes, hvis den er defekt



Max. Belastung
Max. load
Charge max.
Max. belasting
Portata max.
Carga máx.
Peso máximo
Max. belastning
Maks. kuormitus
Maks. belastning
Maks. belastning



Absturzgefahr
Danger of falling
Risque de chute
Risqué de chute
Gevaar voor vallen
Pericolo di caduta
Perigo de caída
Perigo de cair
Risk att ramla
Putoamisvaara
Fare for å falle
Fare for at falde ned

Lieferumfang
Scope of delivery
Volume de livraison
Omvang van de levering
Fornitura
Volumen de entrega
Volume de entrega
Leveransomfatning
Toimituskokonaisuus
Leveringsomfang
Indeholdt i leveringen

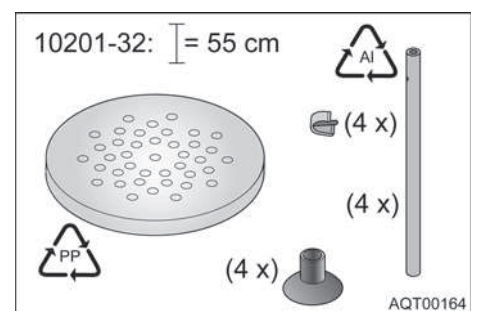
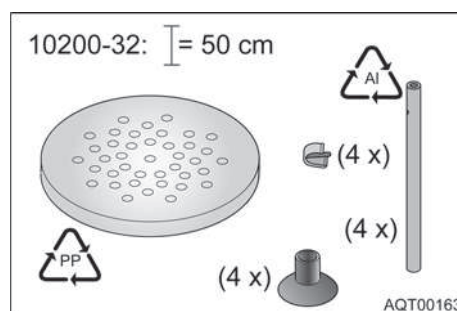

Montieren
Mounting
Montage
Monteren
Montaggio
Montar
Montagem
Montering
Asennus
Montering
Montering

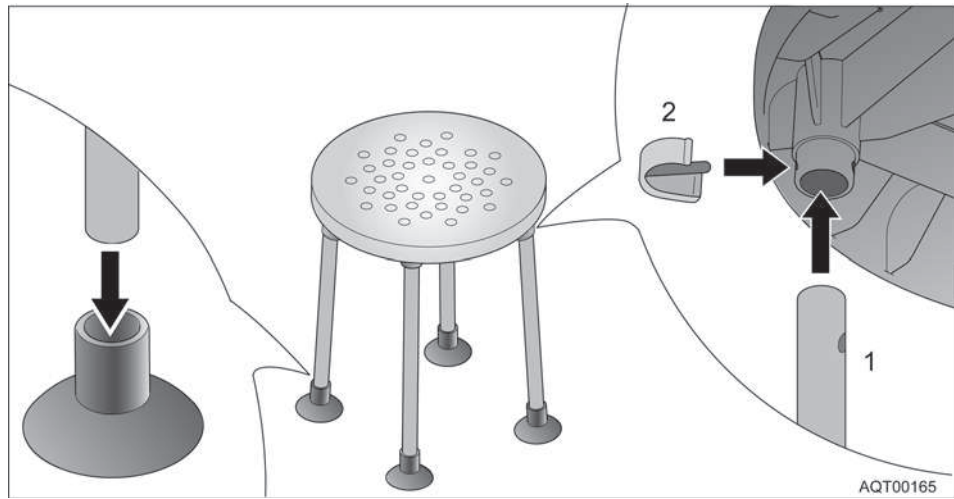

AQT00165

Reinigen
Cleaning
Nettoyage
Reinigen
Pulizia
Limpeza
Limpeza
Rengõra
Puhdistaminen
Rengjøring
Rengjøring



Ohne Scheuermittel reinigen
Clean without scouring agent
Ne pas utiliser de produits récurrents pour le nettoyage
Zonder schuurmiddelen reinigen
Non pulirlo con prodotti abrasivi
No utilizar productos abrasivos para su limpieza
Não utilize produtos de limpeza abrasivos
Använd inte skurmedel
Puhdisti ilman hankausaineita
Bruk ikke skuremiddel ved rengjøring
Rengør uden skuremiddel

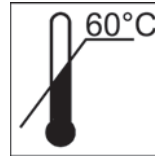

Reinigungstemperatur max. 60 °C
Max. cleaning temperature: 60 °C
Température de nettoyage 60 °C max.
Reinigungstemperatuur max. 60 °C
Temperatura max. durante la pulizia 60 °C
Temperatura máx. de limpeza 60 °C
Temperatura máxima de limpeza 60 °C
Rengjøringstemperatur max 60 °C
Puhdistuslämpötila maks. 60 °C
Temperatur ved rengjøring maks. 60 °C
Rengjøringstemperatur maks. 60 °C



Von Hand reinigen
Clean by hand
Nettoyage à la main
Handmatig reinigen
Pulizia a mano
Limpiar a mano
Limpeza manual
Rengør for hånd
Puhdisti käsin
Rengjør manuelt

D

Invacare GmbH
Alemannenstraße 10
D-88316 Isny
Telefon 07562 700-0
Telefax 07562 700-66
E-Mail kontakt@invacare.com
Internet www.invacare.de

CH

INVACARE® AG
Benkenstrasse 260
CH-4108 Witterswil
Telefon 061 487 70 80
Telefax 061 487 70 81
E-Mail switzerland@invacare.com
Internet www.invacare.ch

A

INVACARE® AUSTRIA GmbH
Herzog Odilostraße 101
A-5310 Mondsee
Telefon 06232 5535-00
Telefax 06232 5535-4
E-Mail info@invacare-austria.com
Internet www.invacare-austria.at

FIN

Algol-Trehab Oy
Karapellontie 6
02610 Espoo
Puhelin 09 50991
Faksi 09 5099490
Sähköposti info.algolrehab.fi@algol.fi
Internet www.algolrehab.fi

F

INVACARE® Poirier S.A.S.
Route de St Roch
F-37230 Fondettes
Téléphone 0247 626466
Téléfax 0247 421224
E-mail contactfr@invacare.com
Internet www.invacare.fr

DK

INVACARE® A/S
Sdr. Ringvej 37
DK-2605 Brøndby
Telefon 036 90 00 00
Telefax 036 90 00 01
E-mail denmark@invacare.com

S

INVACARE® AB
Fagerstagatan 9
S-163 91 Spånga
Telefon 08 761 70 90
Telefax 08 761 81 08
E-Post sweden@invacare.com
Hemsida www.invacare.se

CDN

INVACARE® CANADA INC.
570 Matheson Blvd. E., Unit 8
CDN Mississauga
On. L4Z 4G4
Telephone 0905 8908300
Telefax 0905 8905244
Internet www.invacare.ca

E

INVACARE® S.A.
c/Areny
s/n - Poligon Industrial de Celrà
E-17460 Celrà (Girona)
Teléfono 972 493200
Telefax 972 493220
E-mail contactsp@invacare.com
Internet www.invacare.es

N

INVACARE® AS
Grensesvingen 9
Postboks 6230, Etterstad
N-0603 Oslo
Telefon 22 57 95 00
Telefax 22 57 95 01
E-mail norway@invacare.com
Hjemmeside www.invacare.no

NL

INVACARE® BV
Celsiusstraat 46
NL-6716 BZ Ede
Telefoon 0318 695 757
Fax 0318 695 758
E-Mail nederland@invacare.com
csede@invacare.com

GB

INVACARE® Limited
Pencoed Technology Park
Pencoed
UK-Bridgend CF35 5HZ
Telephone 01656 776200
Telefax 01656 776201
E-mail uk@invacare.com
Internet www.invacare.co.uk

P

INVACARE® Lda
Rua Estrada Velha, 949
P-4465-784 Leça do Balio
Telefone 225 1059 46/47
Telefax 225 1057 39
E-mail portugal@invacare.com
Internet www.invacare.pt

I

INVACARE® Mecc San s.r.l.
Via dei Pini, 62
I-36016 Thiene (VI)
Telefono 0445 380059
Telefax 0445 380034
E-mail italia@invacare.com
Internet www.invacare.it

USA

CLARKE HEALTH CARE PRODUCTS Inc.
1003 International Dr.
USA-Oakdale, PA 15071-9226
Telephone 0724 69 52 122
Telefax 0724 69 52 922
E-mail info@clarkehealthcare.com
Internet www.clarkehealthcare.com